

PIM-Digital Process Input Meter

- ACCEPTS 4 INPUT SIGNALS.
- 4-20mA; 0-10VDC; 4 -12-20mA; 0-20mA.
- 4- DIGIT 0.56" RED SUNLIGHT READABLE DISPLAY.
- TWO SETPOINT ALARM OUTPUTS.
- 230 VAC INPUT POWER MODELS.
- SUNLIGHT REALABLE DISPLAY MODELS.
- PROGRAMMABLE DISPLAY & FUNCTION KEYS
- 2 RELAY N/O OUTPUT
- IP51 SEALED FRONT BEZEL



General Description

The PIM Process Input Meter offers many features and performance capabilities to suit a wide range of industrial applications. Multi voltage Powered from 48-240 VAC/DC, the meter has the capability to accept 4-20 mA, 0-10VDC, 4-12-20 mA or 0-20 mA input signals. Each input signal can be independently scaled and – displayed. Any of the 4 values can have Alarms. The meters employ a bright 0.56" (12.7 mm) LED display. The meter has two set point. Outputs, provide dual FORM-C relays (8A). The set point alarm can be configured to suit a variety of control and alarm requirements. Once the meters have been initially configured, the parameter list may be locked out from further modification. The meters have been specifically designed for harsh industrial environments. With IP51 sealed bezel and extensive testing of noise effects to CE requirements, the meter provides – a tough yet reliable application solution.

Safety Summary

All safety related regulations, local codes and instructions that appear in this literature or on equipment must be observed to ensure personal safety and to prevent damage to either the instrument or equipment is used in a manner not specified by the manufacturer, the protection provides by the equipment may be impaired.



CAUTION! Read complete instruction prior to installation and operation of the unit.



CAUTION! Risk of electric shok!

General Meter Specification

- 1.DISPLAY: 4 digit, 0.56" (14.2 mm)
 - a.Red LED(-999 to 9999)
- 2.PASSWORD: Programmable passwords restrict modification of programmed settings.
- 3.ANNUNCIATOR:
 - It- mode type
 - PASS- pass word
 - D.P.- decimal point set up
 - HI- upper reading set up
 - LSP1- relay set point 1
 - LSP2- relay set point 2
 - HY-1- Hysteresis set relay 1
 - HY-2- Hysteresis set relay 2
- 4.KEYPAD: Four front panel buttons
- 5.A/D CONVERTER: 20.000 resolution.
- 6.DISPLAY MESSAGES: "- - - -" Appears when measurement exceeds signal rang.
- 7.INPUT impedance:

ImpedanceMode type	
100Ω	4-20mA
100Ω	4-12-20mA
20KΩ	0-10v
20KΩ	0-20mA
- 8.CONSTRUCTION:

Self-extinguishing plastic housing UL 94V-0 acc IEC 529, color: black. This unit is rated for IP50 (body end cover) IP51 front bezel.
- 9.MOUNTING: 1/8 DIN panel cutout required: 3.622" x 1.772" (92mmx 45mm). Two panel mounting bracket assemblies are provided.

PIM



10.CERTIFICATIONS AND COMPLIANCES:

CE approved.

EN 61326-1 Immunity to industrial Locations conform to standards: IEC 61010-1 Safety requirements for measurement, control and laboratory use part 1.

IP51 Enclosure rating (face only)

IP20 Enclosure rating (rear of unit)

11.ENVIROMENTAL CONDITIONS:

Operating temperature range:

- 40°C to 65°C

Storage temperature range:

- 40°C to 85°C

Relative humidity:

0-90% non-condensing.

12.CONNECTION:

Terminal: Acc IEC 60947-7-1, IEC 60998-1 24~12 AWG/ 0.14~2.5 mm² cop

Tightening Torque: 0.5 Nm.

13.ISOLATION: 4KW input-to-power line, 500V input- to- output or output- to - P+ supply.

14.POWER: 240VAC or 110VAC , or 24VAC, 24VDC or 12VDC

Rated power consumption: 2.4 VA

Rated frequency for as voltage: 48 to 55

15.FUSE: Required external fuse: UL Recognized, 2A max, slow-blow.

16.WEIGHT: 9.5 oz. (269g)

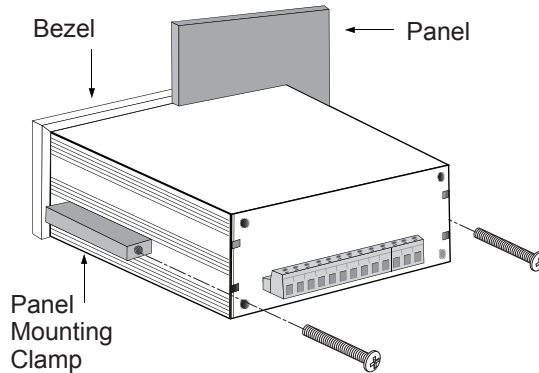

Wiring					
75°C Wire		6mm			
L1 - T1	[mm ²] 0.05 ÷ 4	[mm ²] 0.05 ÷ 4	N.A.		M3 0.5Nm
N, 1, 2, 3 W, X, (+) (-)	[mm ²] 0.05 - 4	[mm ²] 0.05 - 4	N.A.	N.A.	M3 0.5Nm Max
Important: When using electric or pneumatic tools for screw terminals observe max. torque limits					

Installation Environment



The unit should be installed in a location that does not exceed the maximum operating temperature, and provides good air circulation. Placing the unit near devices that regenerate excessive that should be avoided. The front panel should be cleaned only with a soft cloth and neutral soap product. Do NOT use solvents. Continuous exposure to direct sunlight may accelerate the aging process of the panel. Do not use tools of any kind, (screwdrivers, pens, pencils, etc.) to operate the keyboard of the unit

Panel Cut-Out mm [inch]

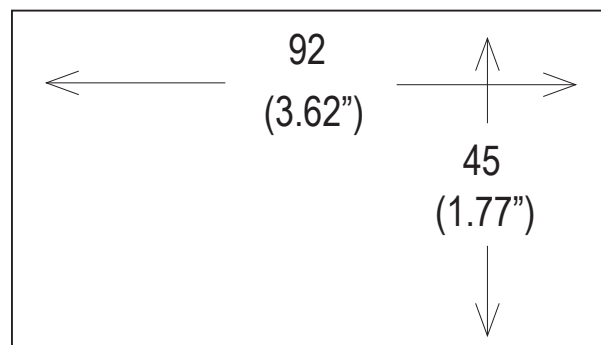

Installing the Meter

Installation.

The PIM unit is intended to be mounted into the enclosed panel. Prepare the panel cutout to the dimensions shown. Remove the panel latch from the unit. Insert the unit into the panel cutout. While holding the unit in place, insert the unit latch on both sides of the unit and tighten the screws evenly until the snug in panel. Do not over-tighten the screws.

Power Wiring



Terminal 1: VAC
Terminal 2: VAC

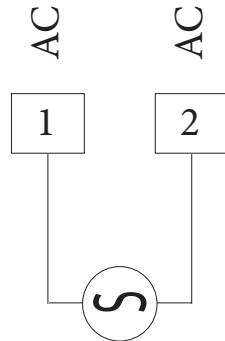

Wiring the Meter

Wiring overview

Electrical connections are made via screw-clamp terminals located on the back of the meter. All conductors should conform to the meter's voltage and current ratings. All cabling should conform to appropriate standards of good installation, local codes and regulations. It is recommended that power supplied to the meter be protected by a fuse or circuit breaker. When wiring the meter, compare the numbers embossed on the back of meter case against this shown in wiring drawings for proper wire position. Strip the wire, leaving approximately 0.3" (705 mm) bare lead exposed (stranded wires should be tinned with solder). Insert the lead under the correct screw clamp terminal and tighten until the wire is secure. (Pull wire to verify tightness.) Each of the relay / measure terminal can accept up to one # 14 AWG (2.55 mm) wire Two #18 AWG (1.02 mm), or four # 20AWG (0.61 mm). The power terminal can accept up to one # 30~16 AWG (0.14~1.5 mm²).

Set Point (Alarm) Wiring

Relay 1: (16) (15) (18)
Relay 2: (26) (25) (28)

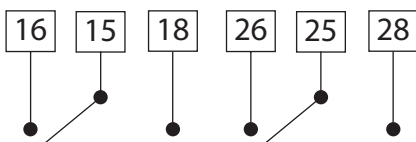

Input Signal Wiring

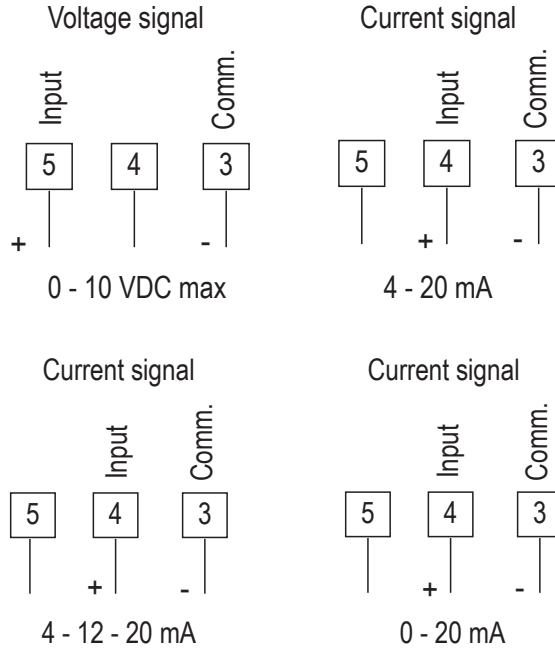

EMC Installation Guidelines

Although this meter is designed with a high degree of immunity to Electro-Magnetic-Interface (EMI), proper installation to ensure compatibility in each application. The type of the electrical noise, its source of the method of coupling into the unit may be different for various installation. Listed below are some EMC guidelines for successful installation in an industrial environment.

1. The meter should be mounted in a metal enclosure, which is properly connected to protective earth.
2. With use of lower input ranges or signal sources with high source impedance, the use of shielded cable may be necessary. This helps to guard against stray AC pick-up. Attach the shield to the input common of the meter.
3. To minimize potential noise problems, power the meter from the same power branch, or at least the same phase voltage as that of the signal source.
4. Never run Signal or Control cables in the same conduit or raceway with AC power lines, conductors feeding motors, solenoids, SCR controls, and heaters, etc. The cable should be run in metal conduit that is properly grounded. This is especially in applications where cable runs are long and portable two-way radios are used in close proximity or if the installation is near a commercial radio transmitter.



5. Signal of control cables within an enclosure should be routed as far away as possible from contactors, control relays, transformers and other noise components.

6. In extremely high EMI environments, use of external EMI suppression devices, such as ferrite suppression cores, is effective. Install them on Signal and Control cables as close to the unit as possible. Loop the cable through the core several times or use multiple cores on each cable for additional protection. Install line filters on the power input cable to the unit to suppress power line interference.

Install them near the power entry point of the enclosure. The following EMI suppression devices (or equivalent) are recommended:

Ferrite Suppression Cores for signal and control cables:

Fair-Rite #0443167251 (RLC # COR0000)

TDK # ZCAT3035-1330A

Line filters for input power cables:

Schaffner #FN2010-1/07 (RLC #LFIL0000)

Shaffner # FN670-1.8/07

7. Long cable runs are more susceptible to EMI pick-up than short cable runs. Therefore, keep cable as short as possible.

8. Switching of inductive loads produces High EMI. Use of Snubbers across in

Reviewing Front Buttons and Display



R1	Red LED	Relay 1 ON
R2	Red LED	Relay 2 ON
Ov	Yellow	Over range
Un	Blue	Under range



Key 1 Quit programming and return to display mode



Key 2 Increment selected parameter









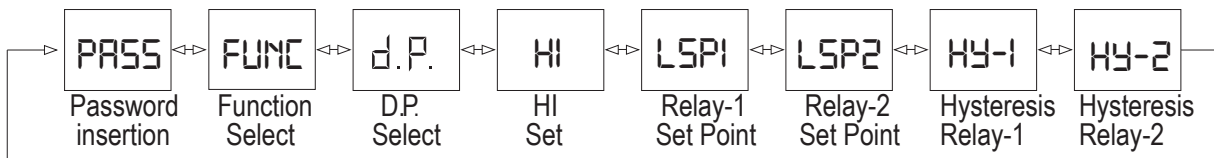





Key 3 Shift right next digit



















Key 4 Set the value recorded



















Programming

Press key	Display view	Explanation
PASSWORD INSERTION		
	PASS	Start entering pass code
	0 000	Segment flashes ready To enter code "1"
	1000	Enter No. "1"
	1 0 00	Segment flashes ready To enter code "2"
	1200	Enter No. "2"
	12 0 0	Segment flashes ready To enter code "3"
	1230	Enter No. "3"
	123 0	Segment flashes ready To enter code "4"
	1234	Enter code completed
	PASS	Confirms pass code
FUNCTION SELECT		
	FUNC	Enter function selection
	Default programm	Segment display Flashes Indicate default programm
		Push the button to Scroll and Select through the Models

Note: PIM have 4 programmes: 0-20 mA, 0-10 VDC, 4-20 mA, 4-12-20 mA (Zero point at 12 mA)

Press key	Display view	Explanation
	FUNC	Function Selected
D.P. SELECT		
	D.P.	Select D.P.
	0 0	Select D.P.
	Press to Select D.P	Using knobs  and  Enter D.P. request
	D.P	
HI SET		
	HI	Enter HI value
	0 000	Segment flashes ready To enter code "4"
	HI	Using knobs  and  Enter the HI level redout request
RELAY-1 SET POINT		
	LSPI	Enter relay - 1 set piont
	0 000	Using knobs  and  Enter the LSPI value request
	LSPI	

Press key	Display view	Explanation
RELAY-2 SET POINT		
	LSP2	Enter relay - second point
	0 000	Using knobs  and  Enter the LSP2 value request
	LSP2	
HYSTERESIS RELAY-1		
	HY-1	Enter hysteresis for Relay-1
	0 000	Using knobs  and  Enter the hysteresis value for relay-1
	HY-1	
HYSTERESIS RELAY-2		
	HY-2	Enter hysteresis for Relay-2
	0 000	Using knobs  and  Enter the hysteresis value for relay-2
	HY-2	
		MOD PIM REDY

Note: At programming mode operation:

If the button wasn't pressed for a logn of 2 minutes,
the measures will exit programming.

To continue programming ,please, enter the password again.

Quick Programming View

Permits viewing all parameters without changing them, this mode help recheck and ensures all data parameters are correct.

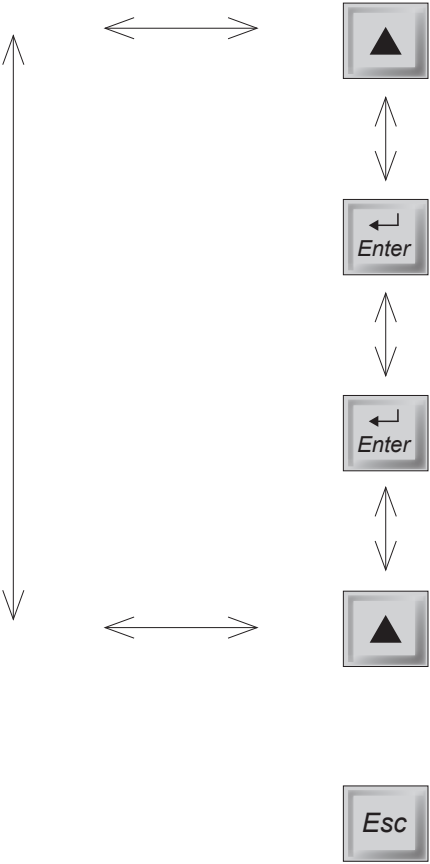
Press	Panel Readout
	PASS
	<p style="text-align: center;">FUNC</p> <p>Receive the function you have choose</p> <p>Back to FUNC</p> <p>Next parametr value</p> <p>At the end push to return to working mode.</p>

Calibration

The meter has been fully calibration at the factory. Scaling to convert the input signal to desired display value according to the TC performed by front panel touch buttons. If the meter appears to be indicating incorrectly or inaccurately, contact technical support at the appropriate company listed.

Troubleshooting

Problem	Remedies
No Display	CHECK: power connection, line voltage
Incorrect Display	VERYFY: input signal



Warning: Calibration of this meter based on software, no extremal meter or signal source is required.

Limited Warranty

The company warrants the products it manufactures against defects in materials and workmanship for a period limited for one year from the date installation, provided the products have been store, handled, installed and used under proper conditions. The company's liability under this limited warranty shall extend only to the repair or replacement of a defective product, at the company's option. The company disclaims all liability for any affirmation, promise or representation with respect to the products. The customer agrees to hold PSK controllers harmless from defend, and indemnify PSK controllers against damages, claims and expenses arising out if subsequent sales of PSK controllers products or products containing components manufactured by PSK controllers and based upon personal injuries, deaths, property damage, lost profits, and other matters which buyer, its employees or sub-contractors are or may be to any extent liable. No warranties or implied are create with respect to the company's products except those expertly contained herein. The customer acknowledges the disclaimers limitations contained herein and relies on no other warranties or affirmations.

Dimensions [mm (inch)]

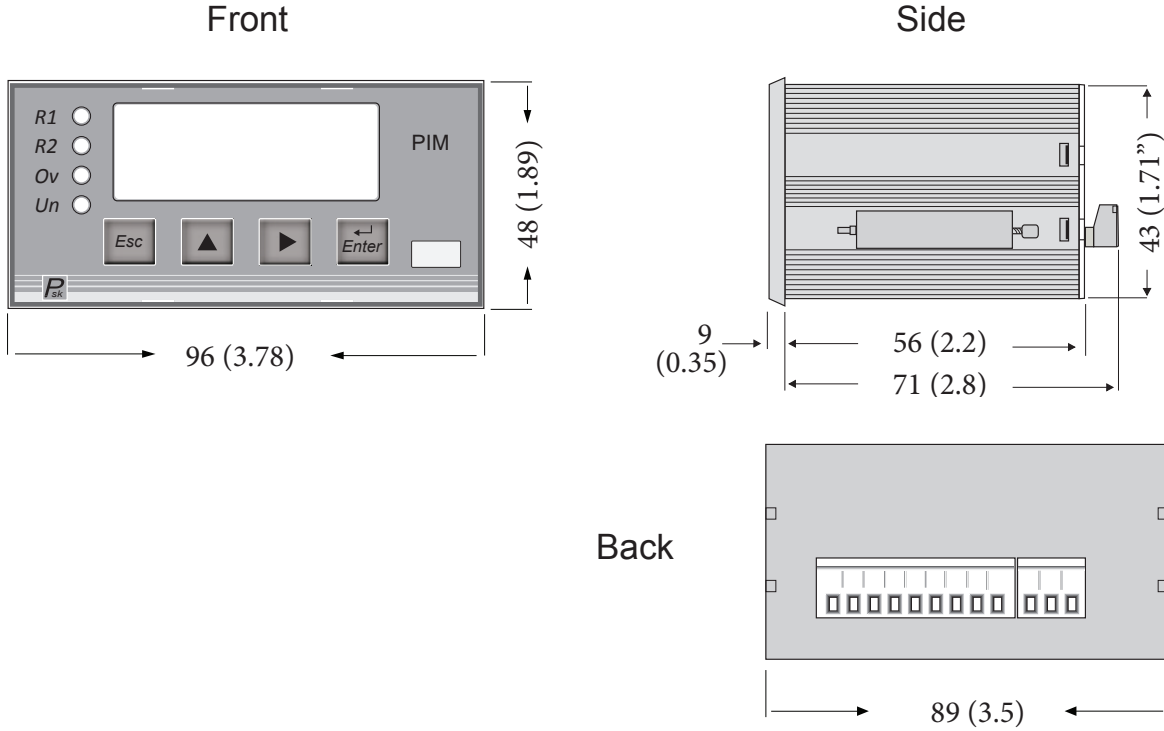

Ordering Information

Indicators

